



2007 International Application Guide • Volume 6 • Issue 1



VL995 VISTA SERIES™

VL995 Vista Series™ Models

VL995IB2740

Useable Platform:
26.75" x 39.75"
(68 cm x 101 cm)

VL995IB2744

Useable Platform:
26.75" x 43.75"
(68 cm x 111 cm)

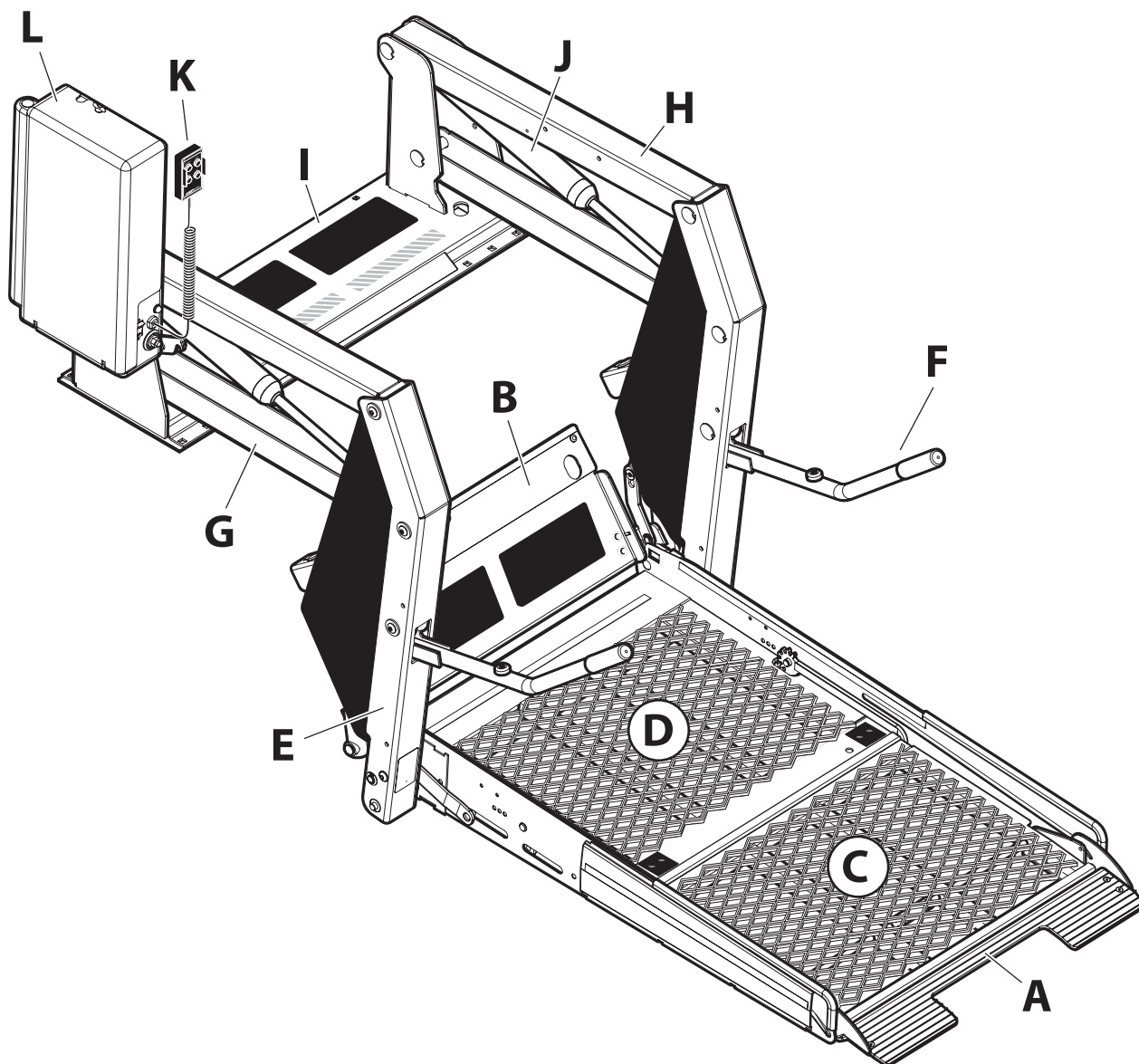

A - Automatic Outboard Roll Stop (ARS)	G - Bottom Parallel Arms (2)
B - Inboard Barrier (IB)	H - Top Parallel Arms (2)
C - Outboard Platform	I - Base Plate
D - Inboard Platform	J - Cylinder (2)
E - Vertical Arms (2)	K - Hand-Held Control Box
F - Handrails (2)	L - Pump Module

Technical Specifications

General Function: Electrohydraulic, power up/gravity down operation

Operation: Hydraulic pump with two lifting cylinders

Control: hand-held control box

Hydraulic: Pressure Max. 2,495 psi (172 bar), Fluid is Univis HVI 26, reservoir is .33 gal (1.25 L)

Construction: Steel structure with powder coat finish

Lift Weight: 246 lbs (111 kg)

Lifting Capacity: 400 lbs (181 kg)

Operating Temperature: 19°F to 149°F (-7°C to 65°C)

Power Supply: 12V DC

Current Consumption: Max. 25A (12V)



Lift Dimensions

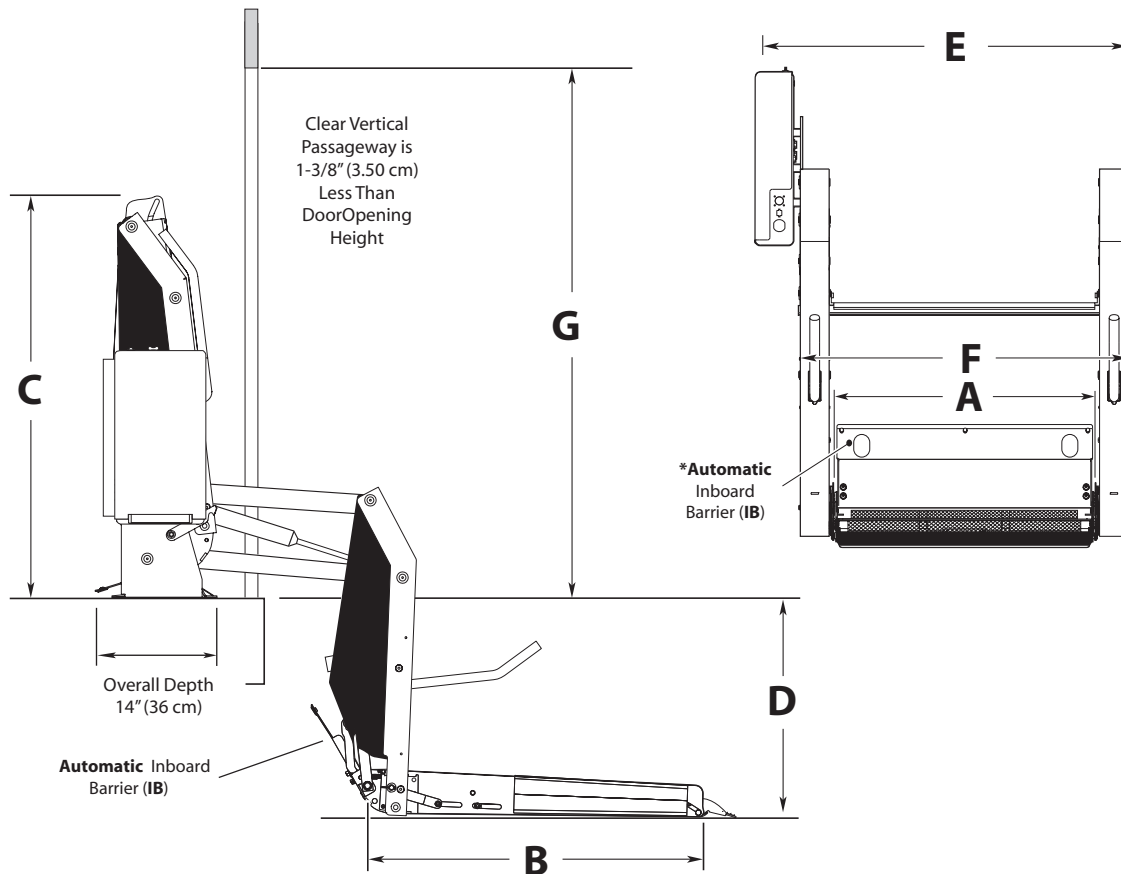

VL995 Vista Series™			A	B	C	D	E	F	G
Lift Model Number	Operation		Clear Platform Width	Clear Platform Length	Overall Lift Height	Max. Floor to Ground	Overall Lift Width	Min. Clear Door Opening Width	Min. Clear Door Opening Height
	User	Attdt.							
VL995IB2740		X	26.75"(68cm)	39.75"(101cm)	44"(112cm)	26.75"(68cm)	40.5"(103cm)	36.5"(93cm)	44.75"(114cm)
VL995IB2744		X	26.75"(68cm)	43.75"(111cm)	48"(122cm)	26.75"(68cm)	40.5"(103cm)	36.5"(93cm)	48.75"(124cm)

All dimensions are for reference only.

VL995 VISTA SERIES™

VL995 Vista Series™ Lift Features



- fully automatic lift, operated by an attendant
- unique stacking platform improves driver and passenger visibility through the window and allows access to the door lock normally blocked by the platform
- parallel arm lift with hydraulic cylinders
- hand-held pendant control box with back-lighted switches for easy operation of the lift
- side or rear door application
- dual handrails for security and convenience
- mechanically operated outer barrier that will be in the fully up position as the platform leaves the ground
- automatic mechanical inboard barrier
- bridging feature permits the wheelchair user to board the lift from sidewalks or inclines
- integrated back-up pump
- equipped with an adjustable anti-rattle feature to avoid unpleasant noise in the vehicle during transit
- durable high-gloss powder coated finish
- Lift-Tite system stows the lift platform securely while the vehicle is in transit
- pump module with removable cover offers easy access to all components
- lift power on/off switch



www.braunability.com/international

ISO 9001:2000

631 West 11th Street, Winamac, IN 46996, USA Phone: +1 574 946 6153 Fax: +1 574 946 4670