



2007 International Application Guide • Volume 5 • Issue 1



MINI-VANGATER SERIES™

Mini-Vangater Series™ Models

MV7688D01

Useable Platform:
25.75" x 32"
(65 cm x 81 cm)

MV7688D96

Useable Platform:
26.5" x 32"
(67 cm x 81 cm)

MV7688FW

Useable Platform:
25.75" x 32"
(65 cm x 81 cm)

MV7688FA

Useable Platform:
26.5" x 38.25"
(67 cm x 97 cm)

MV7688CV

Useable Platform:
25.75" x 32"
(65 cm x 81 cm)

MV7688CA

Useable Platform:
27" x 38.25"
(69 cm x 97 cm)

MV7688D96-FDR*

* Special model
(see chart)

* Developed for a specific application, but may apply to other vehicles.

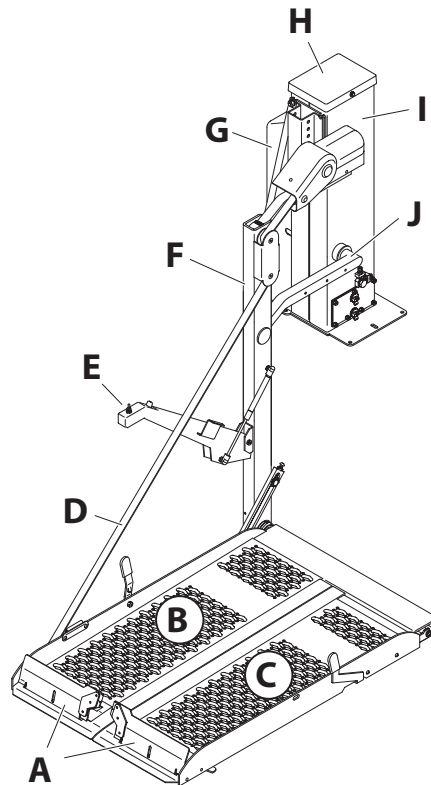

Explanations of abbreviations:

D01 = Dodge/Chrysler Minivans 2001 and up

D96 = Dodge/Chrysler Minivans 1996-2000

FW = Ford Windstar

FA = Ford Aerostar

CV = Chevy Venture

CA = Chevy Astro

FDR = Fiat Doblo Rear Door Application*

A - Outboard Barriers	F - Vertical Arm
B - Platform (Stationary Half)	G - Motor Cover
C - Platform (Folding Half)	H - Top Cover
D - Belt	I - Drive Frame Tube
E - Switch Arm	J - Lift Arm (2)

Lift Accessories



06318-000

Handheld
Pendant Control

Included at no charge when
specified on a lift order



57433-000

Dash-Mounted Toggle Switch

57430-000

Dash-Mounted Touch Pad

Allows independent operation of
all lift functions.



R2003

Remote Control System
(includes keychain transmitter)
(North American Frequency)

57308-000

Replacement Hand-Held

57309-000

Keychain Transmitter



57428-000

Taillight Magnetic Switch Kit



57432-000

Rear Exterior Control with Keylock

Allows operation of all lift functions from outside the van

Technical Specifications

General Function: Electric power up/power down operation

Control: Module mounted switches, Up/Down switch on switch arm, optional hand-held control and remote

Construction: Steel structure with powder coat finish

Lift Weight: 236 lbs (107 kg)

Lifting Capacity: 400 lbs (181 kg)

Operating Temperature: -40°F to 122°F (-40°C to 50°C)

Power Supply: 12V DC

Current Consumption: Max. 85A (12V)



Lift Dimensions

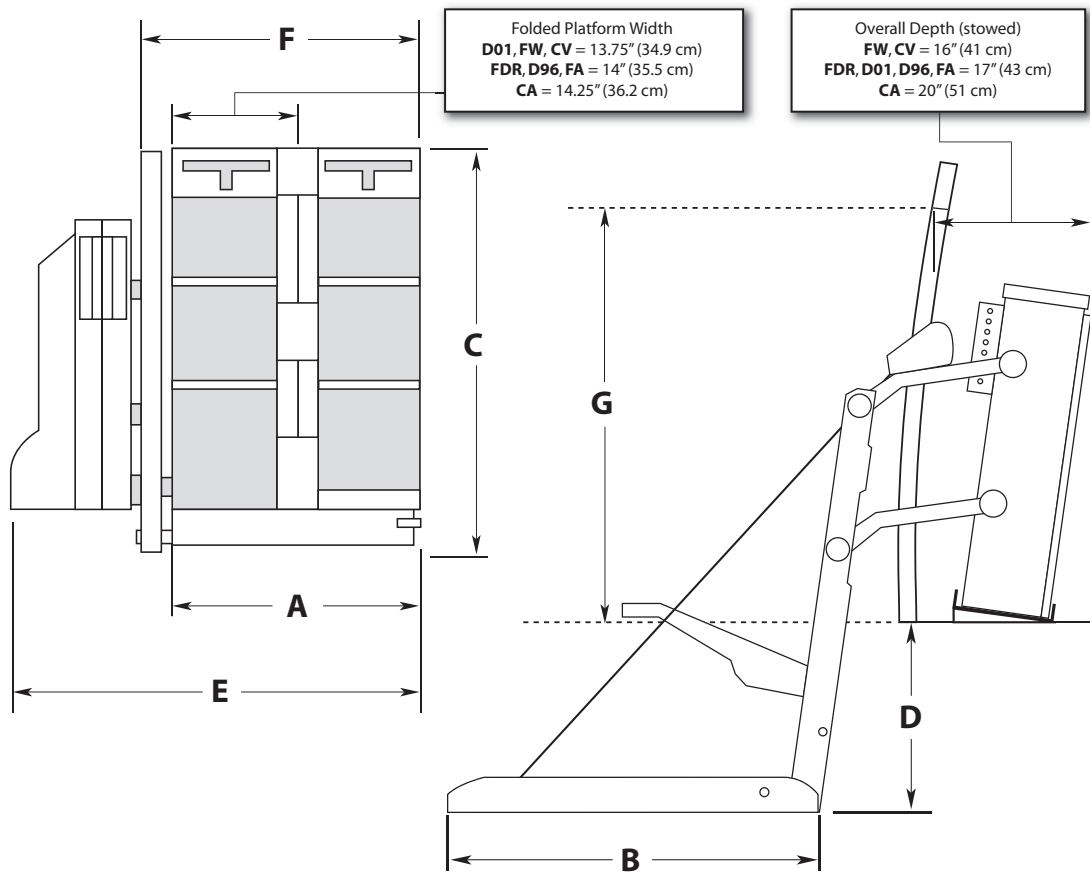

Mini-Vangater Series™			A	B	C	D	E	F	G
Lift Model Number	Operation		Clear Platform Width	Clear Platform Length	Overall Lift Height	Max. Floor to Ground	Overall Lift Width	Min. Clear Door Opening Width	Min. Clear Door Opening Height
	User	Attdt.							
MV7688D01	X	X	25.75"(65cm)	32"(81cm)	43"(109cm)	23.5"(60cm)	44.5"(113cm)	31"(79cm)	43"(109cm)
MV7688D96	X	X	26.5"(67cm)	32"(81cm)	41.5"(105cm)	22.5"(57cm)	45"(114cm)	31.5"(80cm)	41.5"(105cm)
MV7688FW	X	X	25.75"(65cm)	32"(81cm)	43"(109cm)	25.5"(65cm)	44.5"(113cm)	31"(79cm)	43"(109cm)
MV7688FA	X	X	26.5"(67cm)	38.25"(97cm)	46"(117cm)	29.5"(75cm)	45"(114cm)	31.5"(80cm)	46"(117cm)
MV7688CV	X	X	25.75"(65cm)	32"(81cm)	43"(109cm)	25.5"(65cm)	44.5"(113cm)	31"(79cm)	43"(109cm)
MV7688CA	X	X	27"(69cm)	38.25"(97cm)	45"(114cm)	30"(76cm)	45.5"(116cm)	32"(81cm)	45"(114cm)
MV7688D96-FDR*	X	X	26.5"(67cm)	32"(81cm)	41.5"(105cm)	25.5"(65cm)	45"(114cm)	31.5"(80cm)	41.5"(105cm)

All dimensions are for reference only.

MINI-VANGATER SERIES™

Mini-Vangater Series™ Lift Features



- fully automatic lift, operated by the wheelchair occupant or an attendant
- left mounted single post design, provides more usable interior space and offers a clearer view
- manual fold in half platform allows easy access
- hand-held control box with control switches for up/down and in/out
- additional up/down switch mounted on the switch arm
- side or rear door application in mini-vans
- miscellaneous platform widths and lengths
- platform incorporates a passively activated end barrier which acts as the loading and unloading ramps with side panels
- double back-up protection is provided by an efficient manual and speedy auxiliary electric override system
- designed for use with automatic door operators
- durable high gloss powder-coated finish



www.braunability.com/international

ISO 9001:2000

631 West 11th Street, Winamac, IN 46996, USA Phone: +1 574 946 6153 Fax: +1 574 946 4670