



2007 International Application Guide • Volume 6 • Issue 1



L990 MILLENNIUM SERIES™

L990 Millennium Series™ Models

L990RARS

Useable Platform:
27" x 39"
(69 cm x 99 cm)

R = Rear Pump
ARS = Automatic Roll Stop

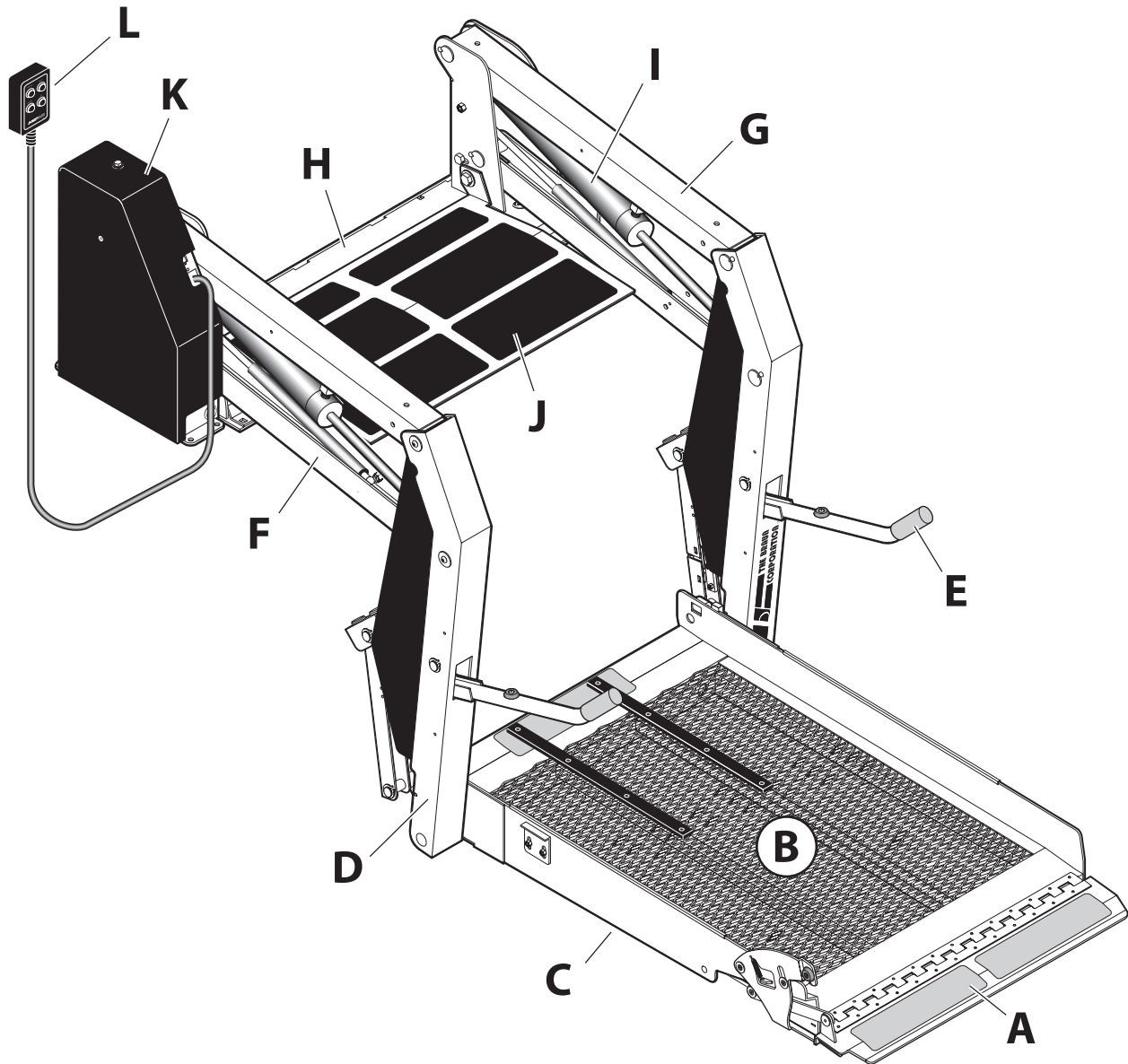

A - Automatic Outboard Roll Stop (ARS)	G - Top Parallel Arms (2)
B - Platform	H - Base Plate
C - Roll Stop Cylinder (Under Platform)	I - Cylinder (2)
D - Vertical Arms (2)	J - Bridge Plate
E - Handrails (2)	K - Pump Module
F - Bottom Parallel Arms (2)	L - Hand-Held Control Box

Technical Specifications

General Function: Electrohydraulic, power up/gravity down operation

Operation: Hydraulic pump with two lifting cylinders and one Roll Stop cylinder

Control: hand-held control box

Hydraulic: Pressure Max. 2,495 psi (172 bar), Fluid is Unavis HVI 26, reservoir is .33 gal (1.25 L)

Construction: Steel structure with powder coat finish

Lift Weight: 295 lbs (134 kg)

Lifting Capacity: 800 lbs (363 kg)

Operating Temperature: 19°F to 149°F (-7°C to 65°C)

Power Supply: 12V DC

Current Consumption: Max. 70A (12V)



Lift Dimensions

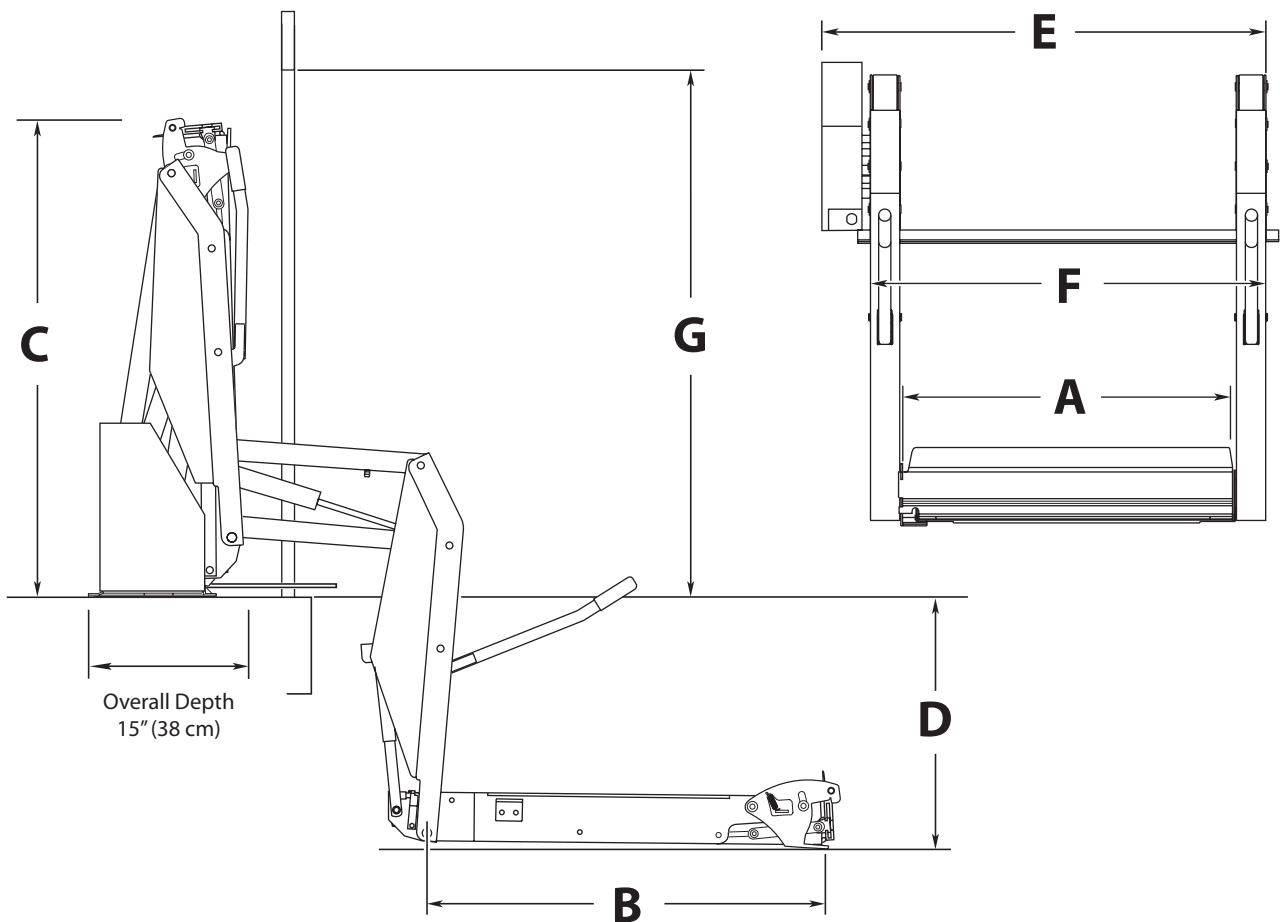

L990 Millennium Series			A	B	C	D	E	F	G
Lift Model Number	Operation		Clear Platform Width	Clear Platform Length	Overall Lift Height	Max. Floor to Ground	Overall Lift Width	Min. Clear Door Opening Width	Min. Clear Door Opening Height
	User	Atttdt.							
L990RARS		X	27"(69cm)	39"(99cm)	44.25"(112cm)	29"(74cm)	39.5"(100cm)	36"(91cm)	44.75"(114cm)

All dimensions are for reference only.

L990 MILLENNIUM SERIES™

L990 Millennium Series™ Lift Features



- fully automatic lift, operated by an attendant
- parallel arm lift with hydraulic cylinders
- hand-held pendant control box with color-coded rocker switches for easy operation of the lift
- side or rear door application
- dual handrails for security and convenience
- hydraulic Automatic Roll Stop (ARS) that will be in the fully up position before the platform leaves the ground
- bridging feature permits the wheelchair user to board the lift from sidewalks or inclines
- integrated back-up pump
- equipped with an adjustable anti-rattle feature to avoid unpleasant noise in the vehicle during transit
- durable high-gloss powder coated finish
- Lift-Tite system stows the lift platform securely while the vehicle is in transit
- pump module with removable cover offers easy access to all components



www.braunability.com/international

ISO 9001:2000

631 West 11th Street, Winamac, IN 46996, USA Phone: +1 574 946 6153 Fax: +1 574 946 4670