



2007 International Application Guide • Volume 6 • Issue 1



CL955 CENTURY XT SERIES™

# CL955 Century XT Series™ Models

## CL955XT3156

Useable Platform:  
31" x 56"  
(79 cm x 142 cm)

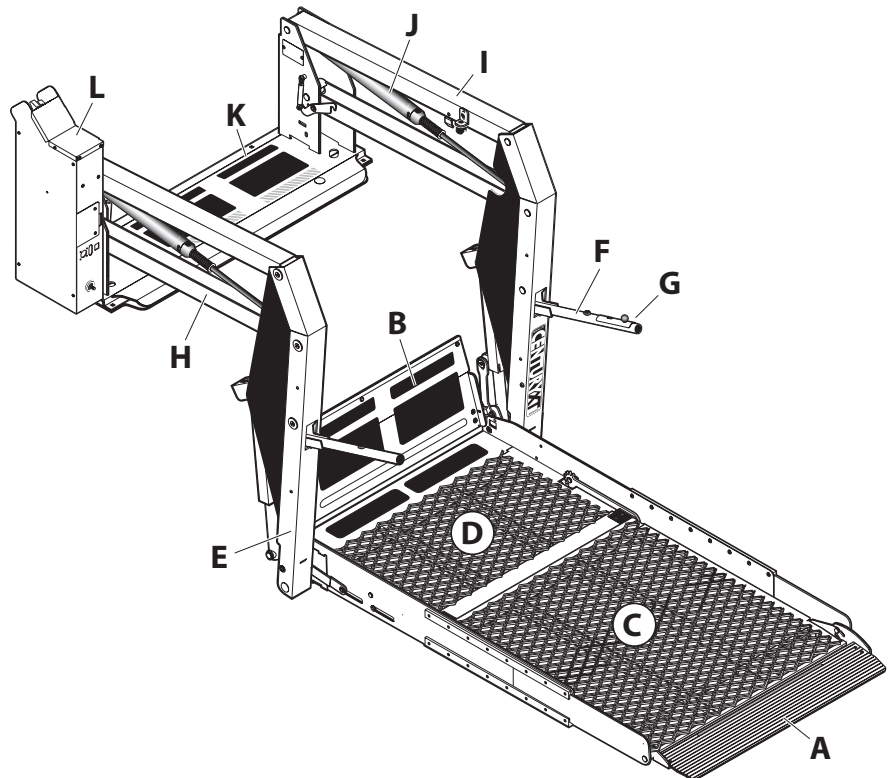

<b>A</b> - Automatic Outboard Roll Stop (ARS)	<b>G</b> - Handrail-Mounted Up/Down Switch
<b>B</b> - Inboard Barrier (IB)	<b>H</b> - Bottom Parallel Arms (2)
<b>C</b> - Outboard Platform	<b>I</b> - Top Parallel Arms (2)
<b>D</b> - Inboard Platform	<b>J</b> - Cylinder (2)
<b>E</b> - Vertical Arms (2)	<b>K</b> - Base Plate
<b>F</b> - Handrails (2)	<b>L</b> - Pump Module & Control Switches

## Lift Accessories



**62400-000**

Side Swing In-Door Operators



**23170A**

Side Slide Door Operator



**15606A** Hand-Held Control Station Kit

- Included at no charge when specified on a lift without door operators
- Controls Lift Functions Only



**26430A** Six-Touch Remote Control System

- Controls all lift functions as well as door operators (if so equipped)
- (North American Frequency)

**26427A** Extra Transmitter for Six-Touch



**26230A**

Threshold Warning Kit

# Technical Specifications

**General Function:** Electrohydraulic, power up/gravity down operation

**Operation:** Hydraulic pump with two lifting cylinders

**Control:** Module mounted switches, handrail Up/Down switch, optional hand-held control and remote

**Hydraulic:** Pressure Max. 2,495 psi (172 bar), Fluid is Unavis HVI 26, reservoir is .33 gal (1.25 L)

**Construction:** Steel structure with powder coat finish

**Lift Weight:** 340 lbs (154 kg)

**Lifting Capacity:** 600 lbs (272 kg)

**Operating Temperature:** 19°F to 149°F (-7°C to 65°C)

**Power Supply:** 12V DC

**Current Consumption:** Max. 70A (12V)



# Lift Dimensions

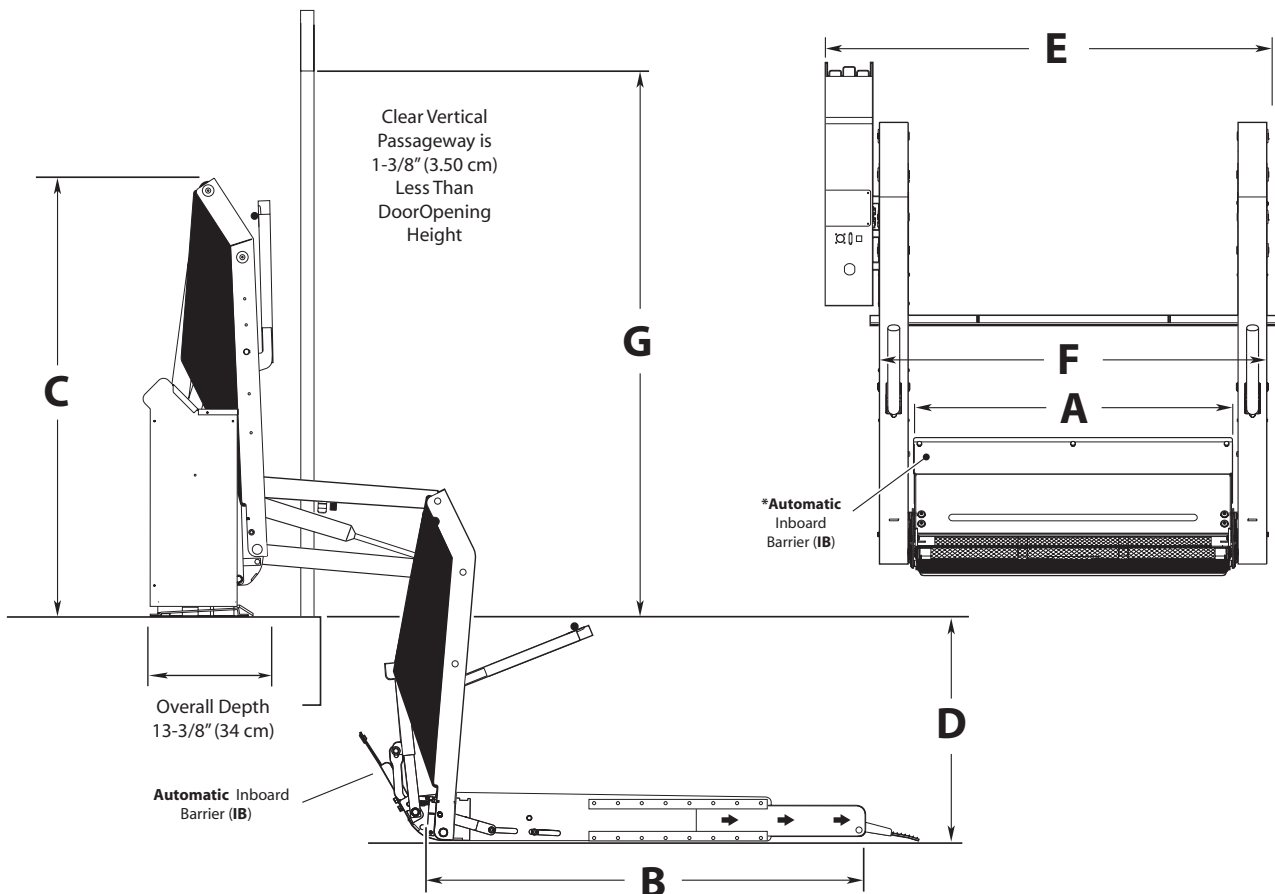

All dimensions are for reference only.

Century XT Series™			A	B	C	D	E	F	G
Lift Model Number	Operation		Clear Platform Width	Clear Platform Length	Overall Lift Height	Max. Floor to Ground	Overall Lift Width	Min. Clear Door Opening Width	Min. Clear Door Opening Height
	User	Attdt.							
CL955XT3156	X	X	31"(79cm)	56"(142cm)	47.25"(120cm)	42"(107cm)	46"(117cm)	40"(102cm)	46.75"(119cm)

CL955 CENTURY XT SERIES™

## CL955 Century XT Series™ Lift Features



- fully automatic lift, operated by the wheelchair occupant or an attendant
- parallel arm lift with hydraulic cylinders
- unique stacking platform allows a 142 cm platform without the need for raised doors
- color-coded rocker switches integrated on the lift
- additional up/down switch is mounted on the handrail
- optional operation by hand-held control box
- optional operation by remote control
- side or rear door application
- dual handrails for security and convenience
- spring-loaded Automatic Roll Stop (ARS) that will be in the fully up position before the platform leaves the ground
- mechanical Inboard Barrier (IB), ensuring extra safety for the wheelchair occupant
- bridging feature permits the wheelchair user to board the lift from sidewalks or inclines
- integrated back-up pump
- designed for use with automatic door operators
- equipped with an adjustable anti-rattle feature to avoid unpleasant noise in the vehicle during transit
- durable high-gloss powder coated finish
- Lift-Tite system stows the lift platform securely while the vehicle is in transit
- pump module with removable cover offers easy access to all components



[www.braunability.com/international](http://www.braunability.com/international)

ISO 9001:2000

631 West 11th Street, Winamac, IN 46996, USA Phone: +1 574 946 6153 Fax: +1 574 946 4670